



The new **standard for clean.**

The steam you need for the laundry and dry-cleaning industries.



The highest quality and performance.

For almost 80 years, Cleaver-Brooks has been setting the new standard for high-performing, quality boiler room products and systems for virtually every industry. With a commitment to technological superiority while reducing operating costs and environmental impact, we always keep the unique needs of every industry in mind. The Laundry and Dry Cleaning segment is one of those industries. Whether it's floor space, fuel options, fuel costs, emissions, or a plug-and-play, pre-engineered package, Cleaver-Brooks has the right option for you. Learn how to make the most of your laundry or dry-cleaning business at laundryanddrycleaningboilers.com.

Meeting The Laundry And Dry Cleaning Industries' Needs At The Right Price

The most fuel-efficient and technologically advanced boilers in the industry

Engineered to perform under the toughest conditions

Meets all environmental regulations

Absolute lowest cost of operation



A boiler is useless if it's unreliable.

The reliability of our boiler products starts with a better engineered boiler. And there simply isn't a better engineered, better manufactured, and more technologically advanced boiler on the market than a Cleaver-Brooks. Of course, genuine Cleaver-Brooks parts and service go a long way in assuring the boiler system stays on line, producing reliable steam year after year.

CLEARFIRE CFH & CFV



The **ClearFire V** is the most technologically advanced vertical boiler ever built.

The **ClearFire H** features all the technology of the CFV in a dependable horizontal design.

10–60 HP

Absolutely the most fuel-efficient boilers in the industry.

Ultra-low emissions come standard.

A boiler quieter than most washing machines—less than 70 dB.

Sealed combustion eliminates need for dedicated boiler room.*

*Varies by local code.

Advanced Technology Comes Standard

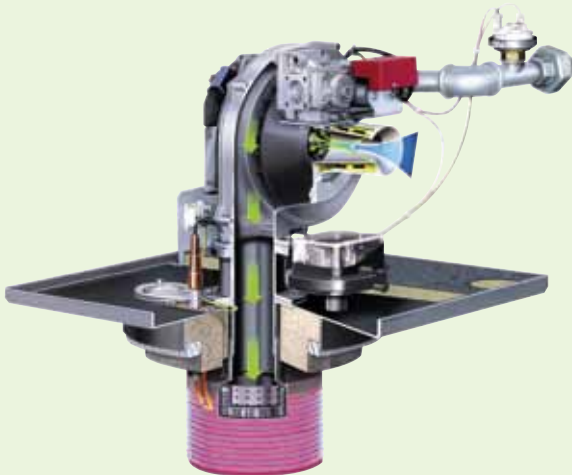

Advanced Burner Technology

Premium metal alloy mesh burner premixes air and fuel for the ultimate in fuel savings.

Variable-speed motor modulates burner to precisely match steam production to demand, reducing fuel usage.

Low-emissions burner meeting all state and federal environmental regulations comes standard.



Patented Heat Transfer for Ultimate Efficiency

Patented AluFer[®] technology achieves optimal heat transfer in the boiler.

Superior heat transfer means a boiler with unrivaled efficiency.

Superior to all conventional tube and tubeless boilers.



Falcon Touch-Screen Control

Advanced microprocessor control comes standard.

Color touch-screen control operates boiler as efficiently as possible.

Simple and easy to use.

Built-in safety features with alarm history.

SIMPLE DESIGN. HIGH PERFORMANCE.

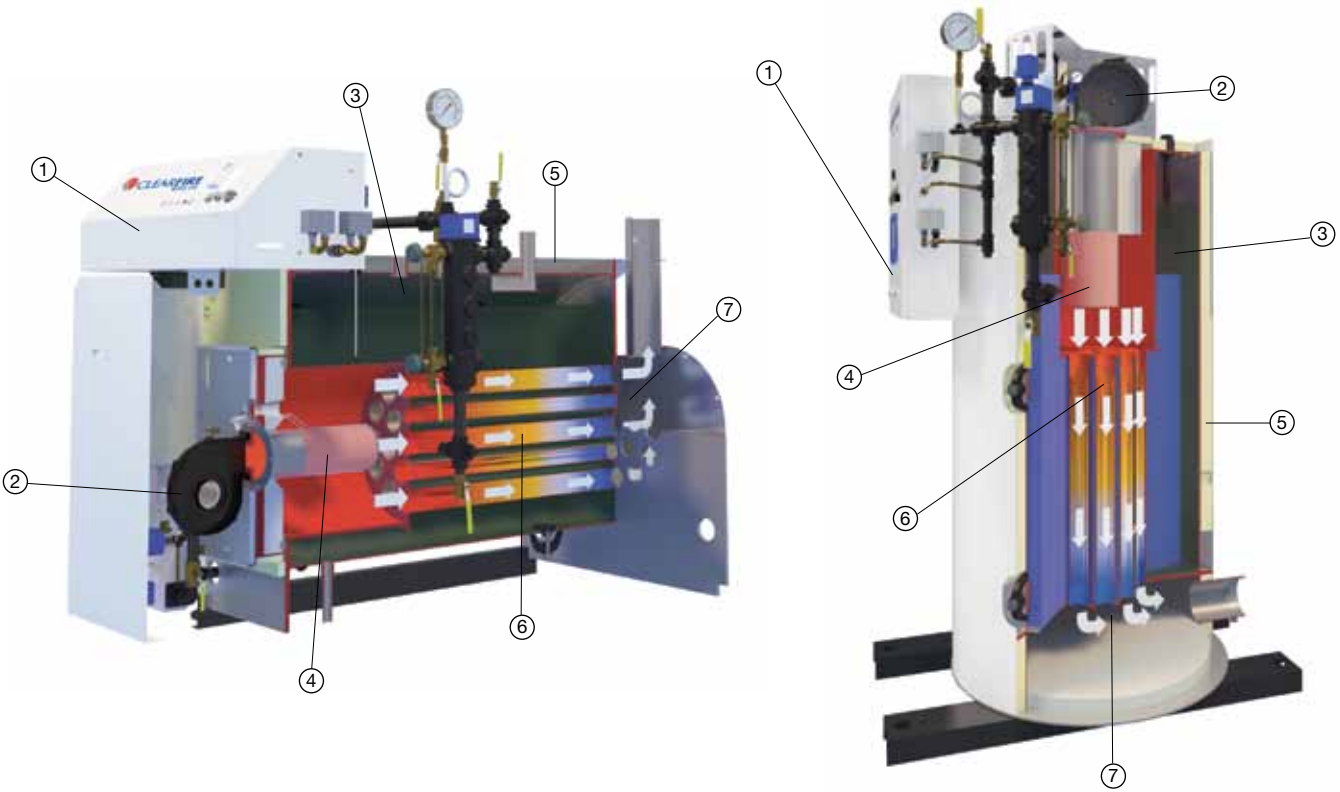

CFH and CFV Features

- 1) Simple, Single-Point Electric Connection
- 2) Sealed Combustion Option
- 3) Large Steam Space for rapid response
- 4) Ultra-Low Emissions Premix Surface Burner

- 5) Water-Cooled Design eliminates classic refractory
- 6) Patented AluFer Heat Transfer Technology
- 7) Cold "Sludge Area" minimizes hard scale formation

Engineered to outlast under the toughest conditions.

Advanced boiler design dramatically reduces the amount of sludge and scale buildup in the boiler.

Premix surface burner and superior heat transfer prevent damage from overheating.

Water-cooled design with metal casing eliminates refractory in the boiler wall.

The absence of dampers and linkages provides a more reliable and maintenance-free boiler.

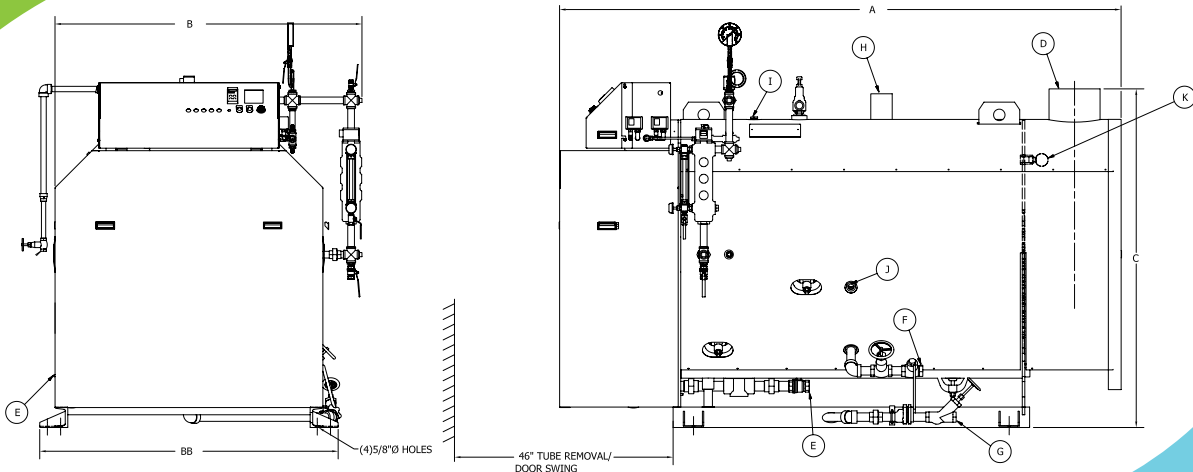

ClearFire CFH Dimensions and Ratings

Ultra-efficient technology built to last in a horizontal boiler.

Boiler Horsepower	10	15	20	25	30	40	50	60
Dimensions – inches								
Overall Length (A)	86	86	87	87	92	104	110	110
Overall Width (B)	44	44	47	47	55.5	55.5	60.5	60.5
Width (BB) minus water column and blowdown	38	38	41.5	41.5	49	49	55	55
Overall Height (C)	54	54	57	57	66	66	68	68
Connections - inches								
Stack Nominal OD (D)	6	6	6	6	8	8	10	10
Gas Connection (E)	1	1	1	1	1 1/4	1 1/4	1 1/2	1 1/2
Feed Water (F)	1	1	1	1	1	1	1 1/4	1 1/4
Bottom Blowdown (G)	1	1	1	1	1	1	1 1/4	1 1/4
Steam Outlet (H) 15 psig	4	4	4	4	4	6	6	6
Steam Outlet (H) 150 psig	1 1/2	1 1/2	1 1/2	1 1/2	2	2	3	3
Surface Blowoff (I)	1 1/4	1 1/4	1 1/4	1 1/4	1 1/4	1 1/4	1 1/4	1 1/4
Chemical Feed (J)	1	1	1	1	1	1	1	1
Overflow (K)	1	1	1	1	1	1	1	1
Steam Boiler Weights in lbs								
Normal Water Weight - 15 psig	920	920	1,150	1,150	1,710	1,980	2,510	2,510
Normal Water Weight - 150 psig	1,010	1,010	1,250	1,250	1,850	2,150	2,700	2,700
Approx. Shipping Weight	2,450	2,450	2,750	2,750	3,400	3,700	5,200	5,200
Power Requirements (115 V ac, 60 Hz, single phase)								
Blower Motor Size (Watts)*	335	335	335	335	335	750	1,200	1,200
Ratings**								
Rated Capacity–Steam (lbs-steam/hr. from 212°F)	345	518	690	863	1,035	1,380	1,725	2,070
Efficiency %	86.2	85.2	85.6	85.1	85.9	85.8	86.2	85.8
Output (1,000 Btu/hr.)	339	503	674	838	1,015	1,351	1,697	2,027
Input (1,000 Btu/hr.)	394	591	788	984	1,181	1,575	1,969	2,363
Fireside Heating Surface (sq. ft.)	122	122	191	191	310	381	573	573
Turndown/Modulating Firing Range	4:1	4:1	4:1	4:1	4:1	5:1	5:1	5:1

* For altitudes above 1500 ft., contact local Cleaver-Brooks authorized representative for verification of boiler and blower motor size.

** From and at 212°F.

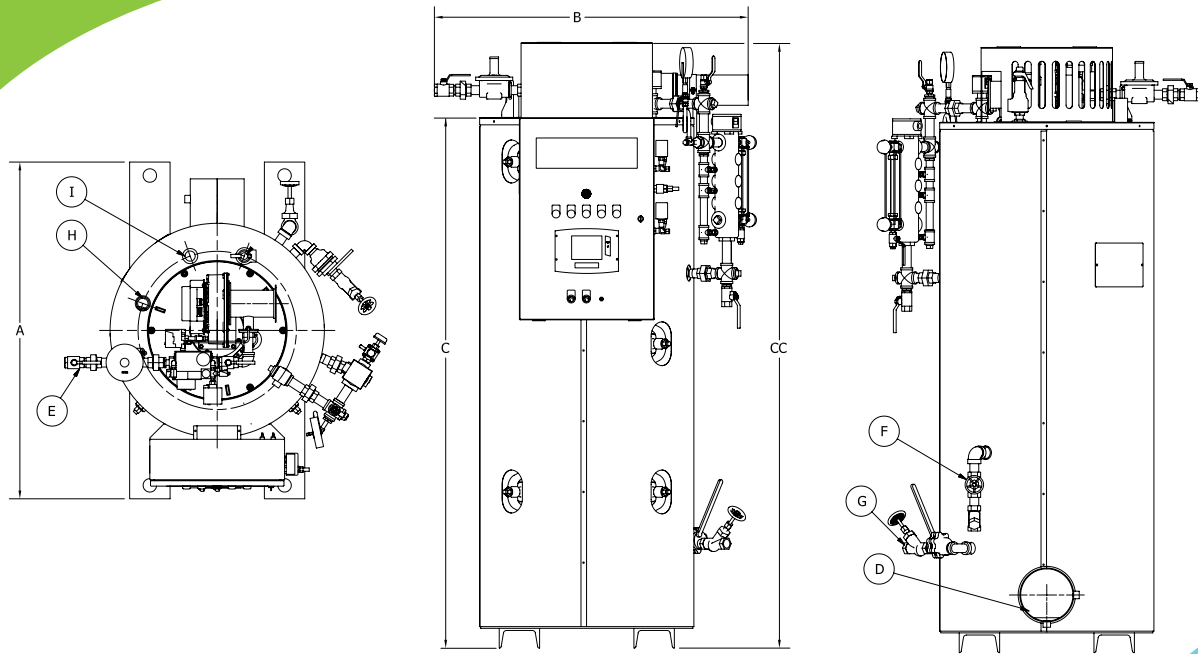

ClearFire CFV Dimensions and Ratings

The power you need, in a compact vertical design.

Boiler Horsepower	10	15	20	25	30	40	50	60
Dimensions – inches								
Overall Length (A)	50	50	55	55	68	68	75	75
Overall Width (B)	32	32	39	39	47	47	56	56
Clearance Height (C)	73	77	73	79	72	78	81	87
Overall Height with Trim (CC)	84	90	84	90	86.5	92.5	99	105
Connections - inches								
Stack Nominal OD (D)	6	6	6	6	8	8	10	10
Gas Connection (E)	1	1	1	1	1 1/4	1 1/4	1 1/2	1 1/2
Feed Water (F)	1	1	1	1	1	1	1 1/4	1 1/4
Bottom Blowdown (G)	1	1	1	1	1	1	1 1/4	1 1/4
Steam Outlet (H)	1 1/2	1 1/2	1 1/2	1 1/2	2	2	3	3
Surface Blowoff (I)	1 1/4	1 1/4	1 1/4	1 1/4	1 1/4	1 1/4	1 1/4	1 1/4
Steam Boiler Weights in lbs								
Normal Water Weight - 150 psig	710	815	1,195	1,365	1,795	2,050	2,715	3,090
Approx. Shipping Weight	2,000	2,120	2,540	2,780	3,690	4,030	5,280	5,740
Power Requirements (115 V ac, 60 Hz, single phase)								
Blower Motor Size (Watts)*	335	335	335	335	335	750	1,200	1,200
Ratings**								
Rated Capacity–Steam (lbs-steam/hr. from 212°F)	345	518	690	863	1,035	1,380	1,725	2,070
Efficiency %	84.9	84.6	83.5	84	84.8	85	83.4	84.1
Output (1,000 Btu/hr.)	338	506	665	837	1,014	1,355	1,662	2,011
Input (1,000 Btu/hr.)	398	598	797	996	1,195	1,594	1,992	2,391
Fireside Heating Surface (sq. ft.)	84	103	128	159	208	258	312	388
Turndown/Modulating Firing Rate	4:1	4:1	4:1	4:1	4:1	5:1	5:1	5:1

* For altitudes above 1500 ft., contact local Cleaver-Brooks authorized representative for verification of boiler and blower motor size.

** From and at 212°F.

Skid package solutions for plug-and-play steam.

Looking for a turnkey steam solution for your laundry? Cleaver-Brooks offers standard and complete steam boiler system skid-mounted packages in gas and propane fuels. A package saves you time installing the system since all you need are power, gas, and water connections. It's the absolute easiest way to get up and running and stay up and running with Cleaver-Brooks quality.

A skid package can include:

- Feed System
- Blowdown Separator
- Chemical Feed System
- Water Softener
- Economizer



THE MOST FUEL-EFFICIENT BOILERS AVAILABLE FOR THE LAUNDRY MARKET.

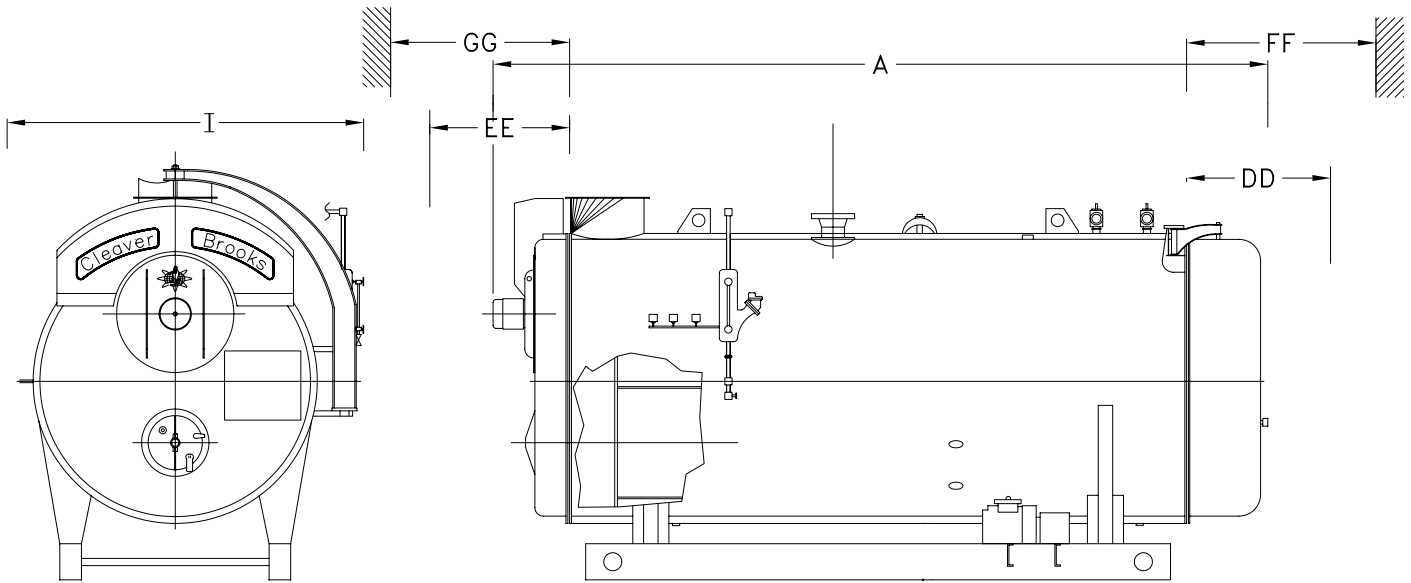

Firetube Model CBR Dimensions and Ratings

Compact firetube solution for larger laundries.

All measurements are provided in inches. Measurements are the same for steam and hot water units except where noted.

Boiler Horsepower	125	150	200	250	300	350
Dimensions - inches						
Overall Length (A) (60 ppm system)	196.5	199.5	231.5	207	226	258
Overall Length (A) (30 ppm system)	199.5	200.5	233.5	211	228	260
Overall Width - HW (I)	75.5	75.5	75.5	82	82	82
Overall Width - Steam (I)	85	85	85	92	92	92
Rear Door Swing (DD)	32	32	32	36	36	36
Front Door Swing (EE)	67	67	67	75	75	75
Tube Removal - Rear (FF)	139	139	170	143	157	187
Tube Removal - Front (GG)	127	127	158	128	142	172
Ratings						
Rated Capacity (lbs-steam/hr. from and at 212°F)	4,313	5,175	6,900	8,625	10,350	12,075
Btu Output (1000 Btu/hr.)	4,184	5,021	6,694	8,368	10,042	11,715
EDR steam gross (sq. ft.)	17,450	20,920	27,900	34,900	41,850	48,820